

5019T Flat Panel Industrial Touch Monitor

DS-501900(F)



19-inch
TFT
SXGA
LCD



Xycom Automation's new 5019T (19") is the latest addition to the high performance, yet cost-effective, 5000 Series of Industrial Flat-Panel monitors. With its two-year warranty and state-of-the-art electronics, the 5019T delivers superb display quality up to 1280 x 1024 (SXGA) resolution with a color depth of 16 million colors and analog resistive touch screen with serial or USB interfaces. The latest generation scaling capability assures high quality, full size images for all standard VESA modes up to SXGA @ 75Hz. Options include 24V DC input power and stainless steel front bezels. The 5019T is certified for NEMA 4/4X/12 environments and meets UL Hazardous Location Class I & II, Division 2 requirements.

Superb Display Quality

The 5019T (19") delivers superb display quality up to 1280 x 1024 (SXGA) resolution with a color depth of 16 million colors and touchscreen with either RS-232 or USB interface. Options include 24V DC input power and stainless steel bezel.

Convert Your 5019 to a Computer Workstation

The 5019T is designed to allow a Xycom 1300 Thin-CLIENT or 1506 Node PC to be mounted on the rear

of the monitor. Just bolt the node to the back of the monitor, attach the cables, and your 5019T becomes a computer workstation.

Fits Your Needs

Other features include Hazardous Location - UL Class I & II, Division 2 compliance; 100mm VESA arm mount provision; and front panel controls, with rear "lock-out" switch, for convenient set up and adjustment. Special mounting clips make the installation of the flat panel monitor quick and simple.

FEATURES

- 2 year warranty on all 5000 Series monitors
- State-of-the-art TFT SXGA color LCD and converter card supporting resolutions up to 1280 x 1024 @ 75Hz, 16 million colors
- Sophisticated scaling engines produce excellent full screen images in all common VESA modes automatically
- Analog resistive touch screen and driver software with choice of RS-232 or USB interface
- Analog Video (VGA) & Digital Video Input (DVI)
- Shallow mounting depth - only 2.85 inches deep
- Provision on the back of the monitor for a 100mm VESA mounting arm, or for mounting a 1300 Thin CLIENT or 1506 Node PC
- Simple installation using mounting clips - no studs
- 24V DC input power option
- Optional stainless steel bezel
- Up to 50' cables (VGA & Serial touchscreen only)
 - DVI Cables limited to 10' (3m) maximum
 - USB Touchscreen Cables limited to 16' (5m) maximum
- Ships standard with 10' VGA, 10' Serial RS-232, & USB Cables (DVI cable must be ordered separately)
- Front panel OSD controls, with rear lock-out switch
- NEMA 4/4X/12 front panel
- UL listed for Hazardous Locations: Class I, Division 2, Groups A, B, C, D; Class II, Division 2, Groups F and G; Temp. Code: T4A

- The 5019T offers VGA video input and Digital Video Input (DVI). All units are shipped with 10-foot VGA and serial cables (DVI cable must be ordered separately). A field-wireable input power receptacle is provided for connection to AC power.



DISPLAY SPECIFICATIONS

Model	5019T
Display Size (Active Area H x W)	14.82" (376.32 mm) x 11.85" (301.056 mm)
Resolution (1 pixel = R+G+B dots)	SXGA: 1280 x 1024
Display Colors	16 million
Brightness	300 Nit Typical
Contrast Ratio	700:1 Typical
Horizontal Viewing Angle	80° Typical
Vertical Viewing Angle	80° Typical
Backlight Life	50,000 Hours



PRODUCT AND MOUNTING DIMENSIONS

5019T Unit Dimensions

Height	15.70" (398.78 mm)
Width	18.51" (470.15 mm)
Mounting Depth	2.85" (72.39 mm)
Weight	21 lbs (9.52 kg)

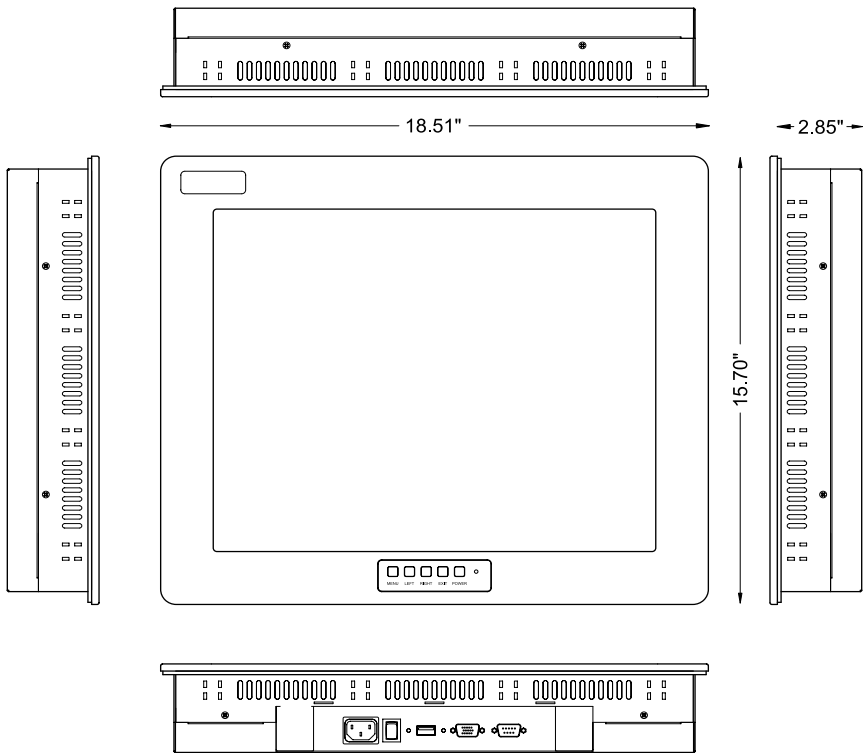

5019T Cutout

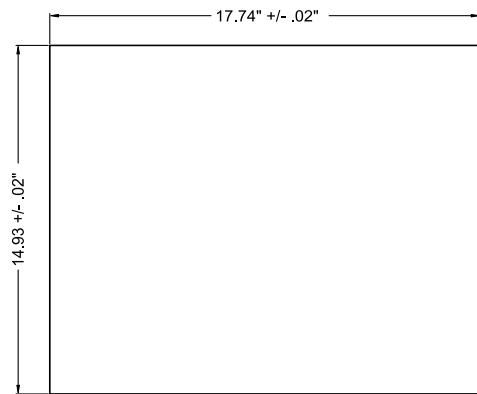

Electrical Connections

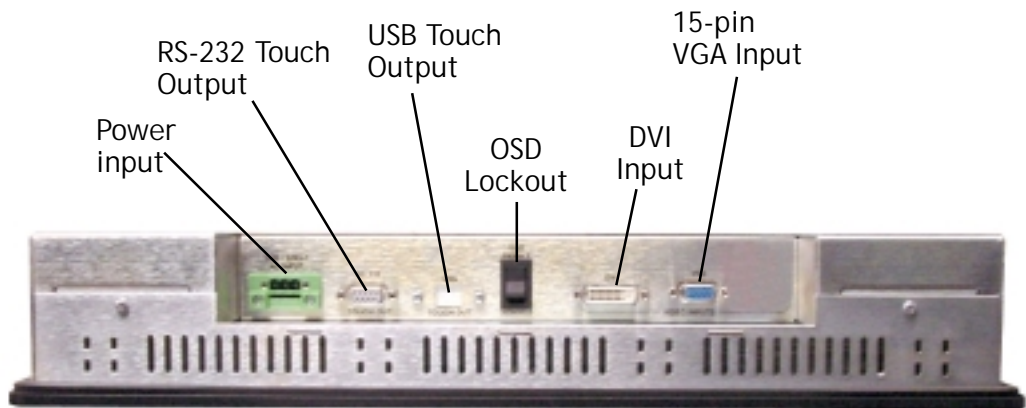

PRODUCT AND MOUNTING DIMENSIONS (CONTINUED)

5019T Mounting Provisions

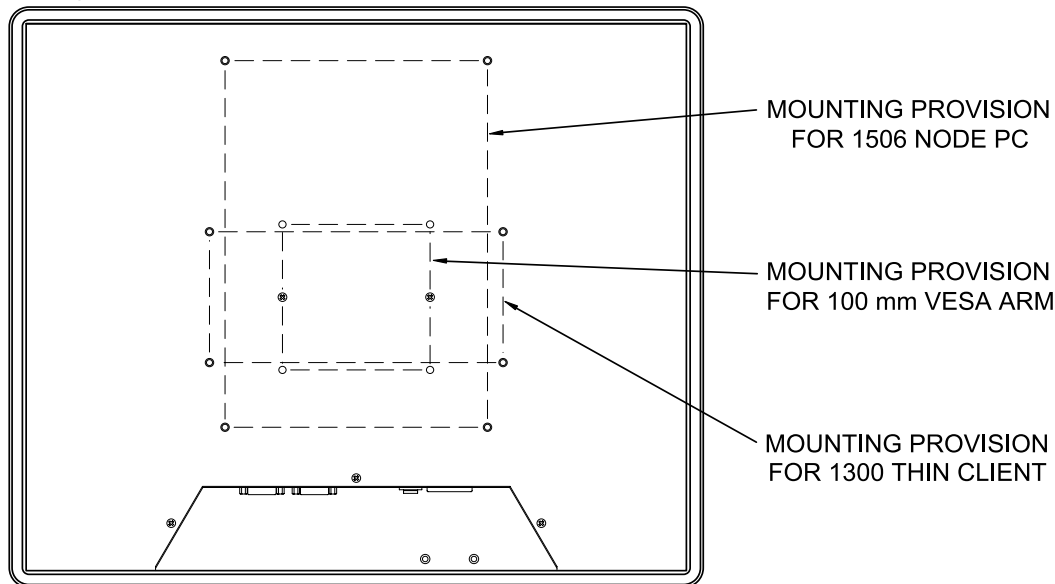

5019T with 1506 Node Box Attached



5019T with 1300 Thin CLIENT Attached



PRODUCT SPECIFICATIONS AND RATINGS

Environmental

	Operating	Nonoperating
Thermal	0°C to 50°C	-20°C to 60°C
Humidity	20% to 80% RH, noncondensing	20% to 80% RH, noncondensing
Shock	15g peak acceleration, 11 msec duration	30g peak acceleration, 11 msec duration
Vibration	0.006" peak to peak displacement	0.015" peak to peak displacement
5-2000 Hz	1.0g maximum acceleration	2.5g maximum acceleration

Electrical

AC power	100 - 240V AC, 0.8A, 50/60 Hz, 50 W nominal*
DC Power	18V DC - 30V DC @ 2.4 A maximum, 53 W nominal*, inrush current = 22 A max @ 24 V DC

* Nominal Power is measured for a base configuration only. Any additional expansion and/or devices will increase the input power required.

Regulatory Compliance

- EN 55022: Class A
- EN 61000-6-2
- EN 61000-3-2, Class A
- EN 61000-3-3
- IEC 60950-1

Safety Agency Approvals:

- UL 508
- UL 1604 ^a
- CSA-C22.2, #142
- CSA-C22.2, #213 ^a



Front Panel

- NEMA 4/4X/12 and IP65

^a Class I Division 2, Groups A, B, C, D; Class II, Division 2, Groups F and G; Temp. Code: T4A

FCC

- 47 CFR, Part 15, Class A

Warning: To maintain a safe condition, do not use USB when the unit is operating in the presence of a hazardous environment.

ORDERING INFORMATION

To create an order number, follow the conventions defined by the example order numbers and product configurations.

Example Order Number

Order Number	Description
5019T	19-inch NEMA 4/4X/12 SXGA (1280 x 1024), 16-million color Class I Div 2, Class II Div 2, color panel mount monitor with analog resistive touch screen and AC power input. Includes 10' VGA cable and 10' RS-232 & USB touchscreen cable, wireable AC input power receptacle, mounting hardware and documentation.

5019T

Power Supply

blank AC Power Supply
-24V 24V DC Power Supply

Bezel

blank Powder-coated Aluminum Bezel
-R Rack Mount Front Panel ^a
-S 304 Stainless Steel Bezel ^b

^a When ordering the Rack Mount Front Panel option, the 5019 is not NEMA rated.

^b Screen adjustment buttons will be mounted on rear with Stainless Steel Bezel option.

Order Number	Description
3000-CBL-03V	3' (1 m) coaxial VGA cable; connects monitor to standard VGA card
3000-CBL-10V	10' (3 m) coaxial VGA cable; connects monitor to standard VGA card
3000-CBL-25V	25' (7.5 m) coaxial VGA cable; connects monitor to standard VGA card
3000-CBL-50V	50' (15 m) coaxial VGA cable; connects monitor to standard VGA card
CBL-SER03MF	3' (1 m) serial communication cable, male to female
CBL-SER10MF	10' (3 m) serial communication cable, male to female
CBL-SER25MF	25' (7.5 m) serial communication cable, male to female
CBL-SER50MF	50' (15 m) serial communication cable, male to female
CBL-USB-03AB	3' (1 m) USB cable, type A to B
CBL-USB-10AB	10' (3 m) USB cable, type A to B
CBL-USB-16AB	16' (5 m) USB cable, type A to B
CBL-DVI-10MM	10' (3m) DVI video cable, connects monitor to DVI VGA card

Xycom Automation, LLC
734-429-4971
Fax: 734-429-1010
<http://www.xycom.com>

Customer Support Hotline:
734-944-0482



© 2006 Xycom Automation, LLC. Specifications may change without notice.

Xycom Automation is a trademark of Xycom Automation. Other brand or product names are the property of their respective owners.